

The information contained in this drawing is the sole property of CWS Coil Winding Specialist.
Any reproduction in part or whole without written permission of CWS Coil Winding Specialist is prohibited.

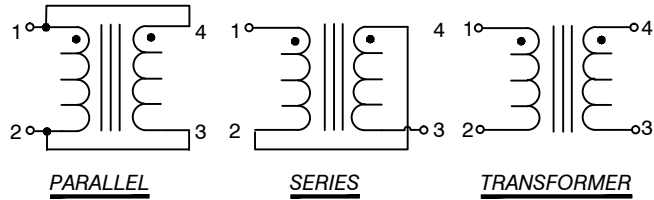

7 BUILT TO RoHS COMPLIANCE AND LEAD FREE.

6 IF APPLICABLE MARK PART NUMBER

5 REMOVE INSULATION AND TIN LEADS

4 WIND ON TO CORE AND EVENLY SPACED CONSTRUCTION:

TO INSURE INTEGRITY OF WINDING SEPARATION
HI-POT TEST FOR WINDING TO WINDING = 300 VDC MIN.
MAX DCR IS $\pm 15\%$ OF TYPICAL VALUE.
SERIES DCR = 0.0207 OHMS TYP @ 20 °C
SERIES RMS CURRENT = 4.62 AMPS.
PARALLEL: (1,4 - 3,2), SERIES: (1 - 3) TIE (2 - 4).
@ 100 KHZ, 0.250 VRMS, 0.0 ADC,
SERIES OPEN CIRCUIT INDUCTANCE = 5.57 μ H $\pm 25\%$,

MAX DCR IS $\pm 15\%$ OF TYPICAL VALUE
PARALLEL DCR = 0.0052 OHMS TYP @ 20 °C,
DELTA TEMP 40 °C, AMBIENT TEMP 85 °C.
PARALLEL RMS CURRENT = 9.23 AMPS @
PARALLEL (1,4 - 3,2), SERIES (1 - 3) TIE (2 - 4).
@ 100 KHZ, 0.250 VRMS, 0.0 ADC,
PARALLEL OPEN CIRCUIT INDUCTANCE = 1.39 μ H $\pm 25\%$,
PARALLEL RATED INDUCTANCE = 1.0 μ H

3 SPECIFICATIONS:

WIRE: UL RECOGNIZED 130°C RATING MAGNET WIRE
CWS BYTEMARK OR OTHER APPROVED PART
CORE: TOROID

2

BOBBIN RATING CLASS B (130°C) REQUIRED
1 MATERIAL: UL RECOGNIZED 94V-0 FOR FLAMMABILITY
NOTES: UNLESS OTHERWISE SPECIFIED.
READ FROM BOTTOM UP.

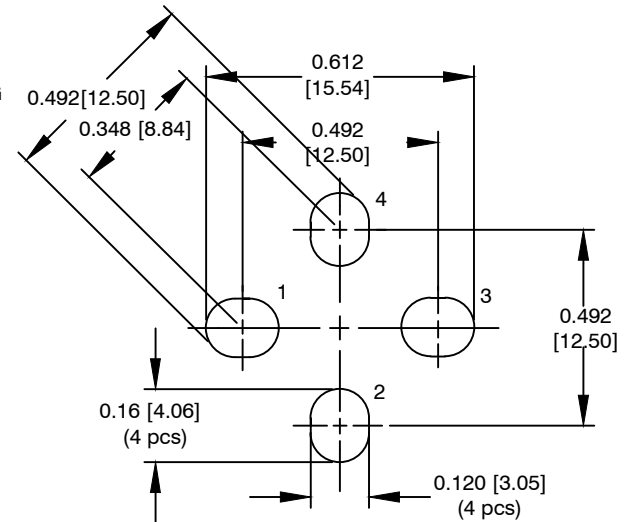
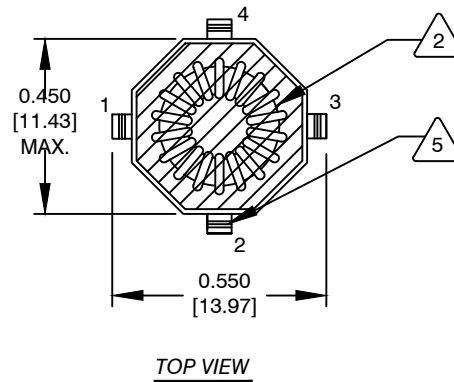
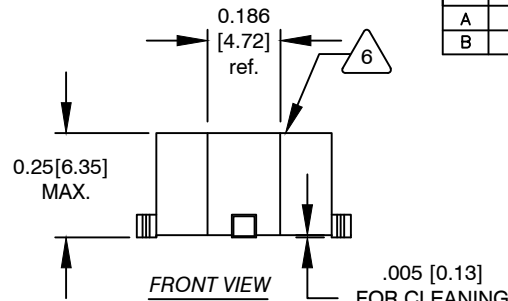

MOUNTING HOLES PATTERN

REVISION HISTORY						
REV	ECN	DESCRIPTION	SIGN & DATE			
			BY	DATE	CHK	DATE
A		PRODUCTION RELEASE	RPR	4/26/05	JLAU	4/26/05
B		FOOTPRINT AND NOTE UPDATE	RJL	4/30/11	JLAU	4/30/11

QTY	CODE IDENT	MFG. P/N	DESCRIPTION	ITEM NO.	
PARTS LIST					
AUTOCAD		X			
SOLIDWORKS					
SIGN		DATE	sales@coilws.com www.coilws.com	Coil Winding Specialist, Inc. 353 W. Grove Avenue Orange, CA 92865	
DRAWN	RPR	4/26/05	Parallel Series Inductor		
CHECKED	JLAU	4/26/05			
ENGR.	KSUM	4/26/05			
APPR.	JLAU	04/28/11			
TITLE:			SIZE DWG. NO.	REV	
			B	CX1-4-HF	B
SCALE			NOT_TO_SCALE	SHEET 1 OF 1	

UNLESS OTHERWISE SPECIFIED
DIMENSIONING AND TOLERANCE PER ANSI Y14.5M
ALL DIMENSIONS ARE IN INCHES AND [MILLIMETERS].
TOLERANCE INCHES:
.XXX = ± 0.010 .XX = ± 0.015 $\angle = \pm 0^{\circ}30'$
TOLERANCE METRICS:
.XXX = ± 0.254 .XX = ± 0.381 $\angle = \pm 0^{\circ}30'$
ANGLE PROJECTION $\angle = \pm 0^{\circ}30'</math>
DO NOT SCALE DRAWING$